



VEILUX®

COLOR DOME CAMERA

SVD-58



SPECIFICATIONS

ITEM	SVD-58	
Signal System	NTSC	PAL
Scanning System	2: 1 Interlace	
Scanning Freq' (H)	15.734 KHz	15.625 KHz
Scanning Freq' (V)	59.94 Hz	50 Hz
Image Sensor	1/3" SONY Super HAD CCD	
Sync. System	Internal	
CCD Total Pixel	811(H) X 508(V) 410K	795(H) X 596(V) 470K
Effective Pixel No.	768(H) X 494(V) 380K	752(H) X 582(V) 440K
Resolution	580 TV Lines	
Video Output	1.0 Vp-p composite video at 75ohm	
S/N Ratio	More than 48db (AGC OFF)	
Lens	Fixed Lens (f=3.8mm)	
Min. Illumination	0.3Lux	
Gain Control	Auto	
Back Light Comp'	Auto	
Electronic Shutter	1/60~1/100,000 sec.	1/50~1/100,000 sec
Focus	Manual	
White Balance	Auto	
In/Out Connector	Power (Red jack), Video (Yellow jack)	
Power Supply	9VDC~15VDC (Recommendation 12VDC)	
Power Consumption	Less than 150mA	
Dimensions	85(Ø) x 76.7(H) mm	
Weight	Approximately 220g	

FEATURES

- 1/3" SONY Super HAD CCD
- Built-in Fixed Lens (f=3.8mm)
- 580 TV Lines
- Min. illumination: 0.3Lux
- Automatic White Balance
- Automatic Gain Control
- Back Light Compensation
- 85mm Dome Size

DIMENSION

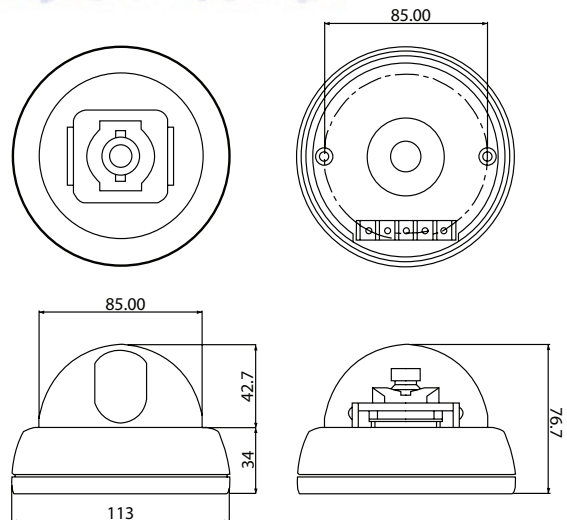

VEILUX®

The Art of Surveillance