



# VEILUX®

## DUAL POWER TRUE DAY & NIGHT WDR 3D DNR VANDAL PROOF DOME CAMERA

### SVV-60CDNL2812D

The Veilux SVV-60CDNL2812D vandal proof dome security camera is heavy duty with superior quality and super wide dynamic range (S-WDR), day/night camera, offering extremely low lux, utilizing 2D/3D digital noise reduction technology. The SVV-60CDNL2812D dome camera is suitable for indoor or outdoor applications. Veilux SVV-60CDNL2812D utilizes the new Veilux WDXV7 DSP chip which features extremely low lux requirements as low as 0.0002 @ 15IRE with up to 512x sens-up. With the new Veilux WDXV7 DSP chip in combination with the Sony Super HAD II CCDs SVV-60CDNL2812D produces superior crisp images over a wide dynamic range of light conditions with extreme back light variations. Veilux SVV-60CDNL2812D camera are ALL IN ONE INCLUSIVE camera covers all required market applications such as retail, banks, transportations, airports as well as mobile applications. The veilux 2D/3D DNR technology utilized in this camera offer hard disk storage savings of up to 75% while recording on motion due to extreme night noise reduction.



Veilux camera designs offer on screen display feature making configuration of advanced feature,s easy to achieve, optimal video quality for all applications. Veilux SVV-60CDNL2812D security cameras are the only all inclusive cameras in the industry to offer one solution suitable for all applications.

## FEATURES

- 1/3" SONY SuperHAD II CCD
- High Resolution 600TV Lines
- Day & Night (ICR-IR Cut Filter Removeable)
- WDR (Wide Dynamic Range)
- 3D-DNR (Digital Noise Reduction)
- Zero Defect
- Eclipse Function
- Digital Zoom (x1 ~ x10)
- Motion Detection
- LSC (Lens Shading Compensation)
- Privacy Mask (Polygonal Mosaic)
- DIS (Digital Image Stabilization)
- O.S.D. Menu Function
- 3-Axis Gimbal
- Sens-Up Function (x512)
- Internal / Line Lock Function
- Backlight Compensation

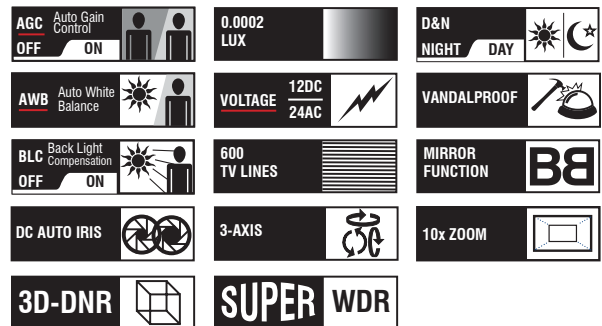

# VEILUX®

The Art of Surveillance

3015 Eagle Drive, Suite 100, Grand Prairie, Texas 75052  
 Local Number: (214) 635-4855 / Fax: (928) 437-6270  
[sales@veilux.net](mailto:sales@veilux.net)  
[www.veilux.net](http://www.veilux.net)



# VEILUX®

## DUAL POWER TRUE DAY & NIGHT WDR 3D DNR VANDAL PROOF DOME CAMERA

### SVV-60CDNL2812D

### SPECIFICATIONS

ITEM	SVV-60CDNL2812D	
Signal System	NTSC	PAL
Image Sensor	1/3" SONY SuperHAD II CCD	
Sync Internal	H/V 15.734 / 59.94 Hz	H/V 15.625 / 50 Hz
Sync Line Lock	H/V 15.750 / 60 Hz	H/V 15.625 / 50 Hz
Scanning System	2:1 Interlace	
Horizontal Resolution	600TV Lines (Max.) / 700TV Lines (B/W)	
Min. Illumination Sense-Up Off	0.12 Lux (15 IRE), 0.2 Lux (30 IRE), 0.4 Lux (50 IRE) F1.2	
Min. Illumination Sense-Up On	0.0002 Lux (15 IRE), 0.2 Lux (30 IRE), 0.4 Lux (50 IRE) F1.2	
Video Output	1.0Vp-p / 75ohm Video 0.714Vp-p	
Y Correction	0.45	
S/N	More than 52dB (AGC OFF)	
O.S.D.	Lens, E-Shutter, Backlight, WDR, AGC, Sens-Up, White Balance, Day & Night, Motion, Mirror, Sharpness, Gamma, Freeze, NEGA, DNR, D-Zoom, LSC, Eclipse, DIS, Privacy, Communication, Sync, Camera-ID, Title	
Electrical Shutter	1/60~1/120,000	1/50~1/120,000
Privacy Masking	8 Windows (Polygonal, 8 Colors)	
Day & Night	Color / BW / Auto / EXT	
Motion Detection	Low, Middle, High, Off (Selectable)	
Digital Zoom	x1.0 ~ x10	
Sens-Up (Low Shutter)	Off ~ x512	
Sync	Auto / Internal / Digital Line Lock	
White Balance	ATW / AWC / Manual / Push	
WDR	On / Off (Step 1, Step 2, Step 3)	
3D-DNR	On / Off (Off, Low, Mid, High)	
LSC / DIS / Eclipse	On / Off	
AGC	Low / Middle / High / Off	
Lens	Aspherical 2.8~12mm DC Auto Iris Lens	
Oper Temp' / Hum'	-20°C ~ 60°C / 30% ~ 80%	
Storage Temp' / Hum'	-30°C ~ 60°C / 20% ~ 90%	
Power (Max.)	12VDC, 260mA / 24VAC, 170mA	
Dimension	145(Ø) x 106mm(H)	
Weight	About 1,040g	

### DIMENSION

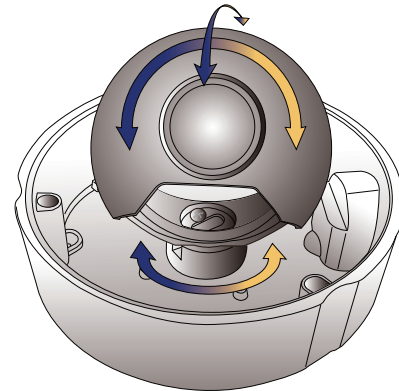
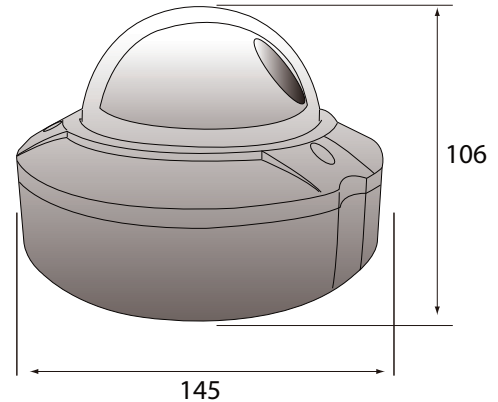

3015 Eagle Drive, Suite 100, Grand Prairie, Texas 75052  
 Local Number: (214) 635-4855 / Fax: (928) 437-6270  
[sales@veilux.net](mailto:sales@veilux.net)  
[www.veilux.net](http://www.veilux.net)



**VEILUX®**  
*The Art of Surveillance*